

# - SERB -



# X-CubeSat II

SERB, a Nano satellite dedicated to Sun-Earth relationship

4<sup>th</sup> Interplanetary CubeSat Workshop  
26 May 2015, South Kensington, London

M. Meftah (CNRS/LATMOS, France)



# Outlines

- 0 – Scientific topics
- 1 – Scientific objectives of the mission
- 2 – Planned schedule
- 3 – SERB nanosatellite
- 4 – Payload
- 5 – Ground segment
- 6 – Conclusions

# 0 – Scientific topics

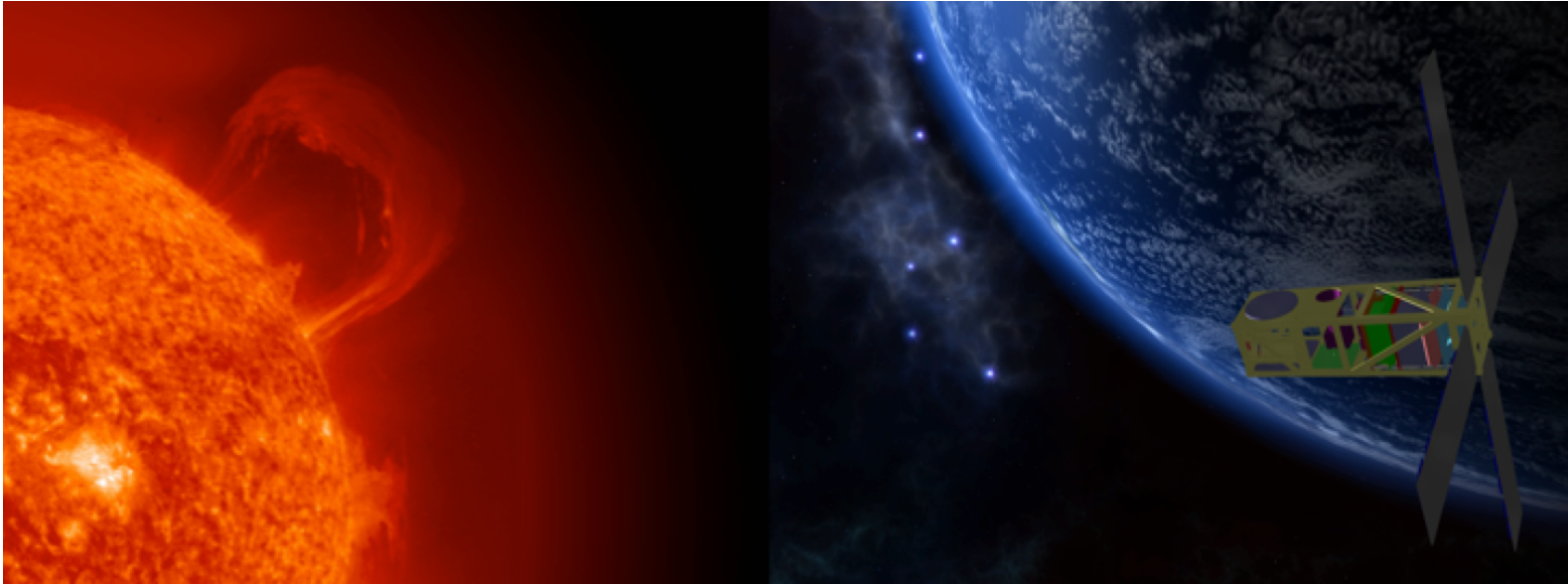

SERB (Solar irradiance and Earth Radiation Budget), a Nano-satellite dedicated to Sun-Earth relationship

## Scientific topics:

Earth observation & Solar physics

# 1 – Scientific objectives of the mission

The « nano-satellite to study the Sun and the Earth » is a future innovative proof-of-concept, with four ambitious science goals:

- *1<sup>st</sup>*: to extend Total Solar Irradiance (TSI) variability measurement,
- *2<sup>nd</sup>*: to improve the knowledge of the absolute value of the TSI (around  $1362 \text{ W/m}^2$ ) and better than  $0.5 \text{ W/m}^2$ ,
- *3<sup>rd</sup>*: to establish a radiation balance of the Earth with an accuracy better than 5%,
- *4<sup>th</sup>*: to understand the relation between solar Ultra-Violet (UV) variability and stratospheric ozone.

# Impact on Earth climate

„Bottom-up“  
TSI (0.1%)

„Top-down“  
UV (6-10%)

Gray, et al. (2010)

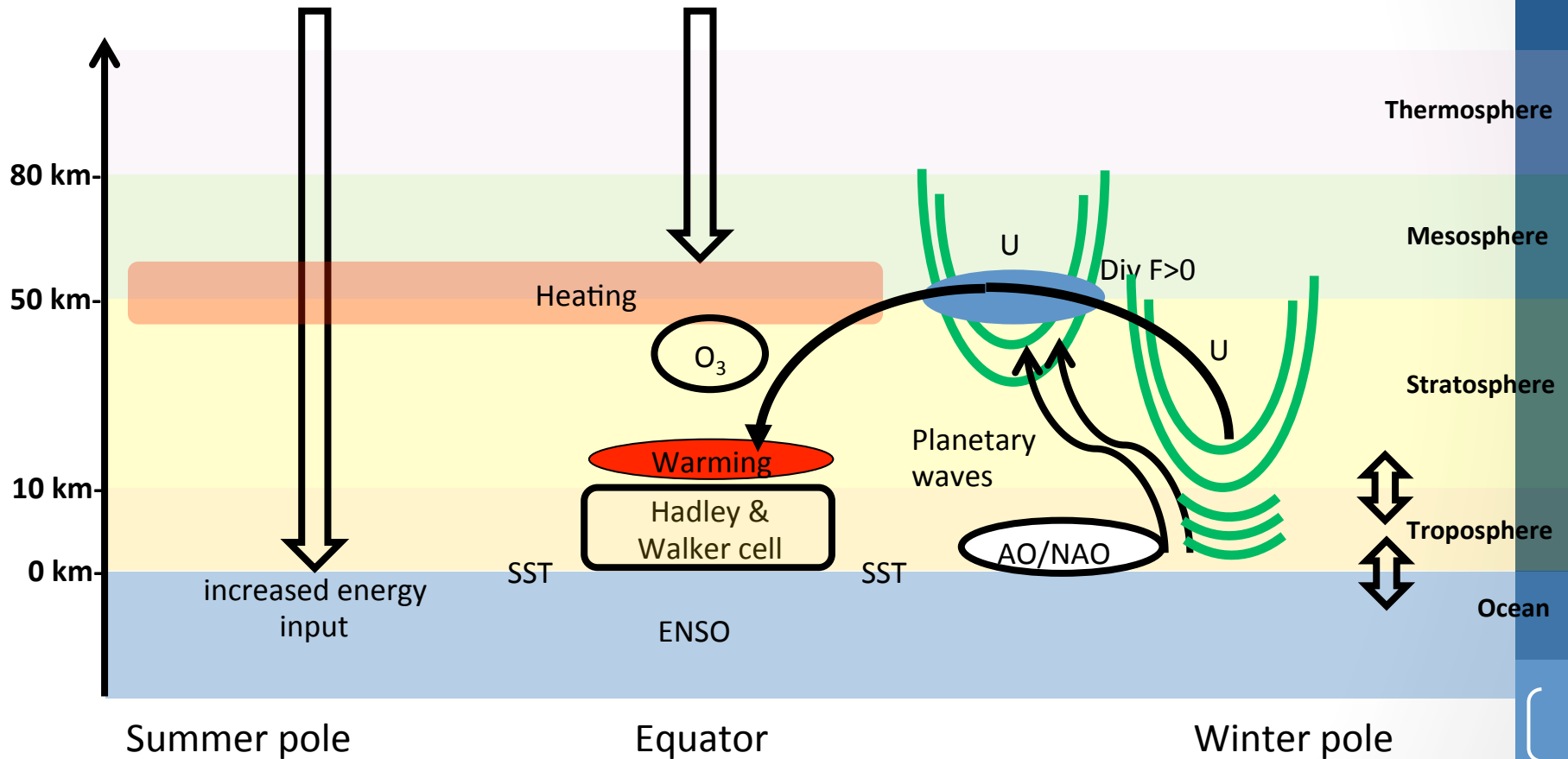

Influence of solar variability on Earth climate.

# 1<sup>st</sup>: to extend TSI measurement

It's important to continue to measure this essential climate variable.

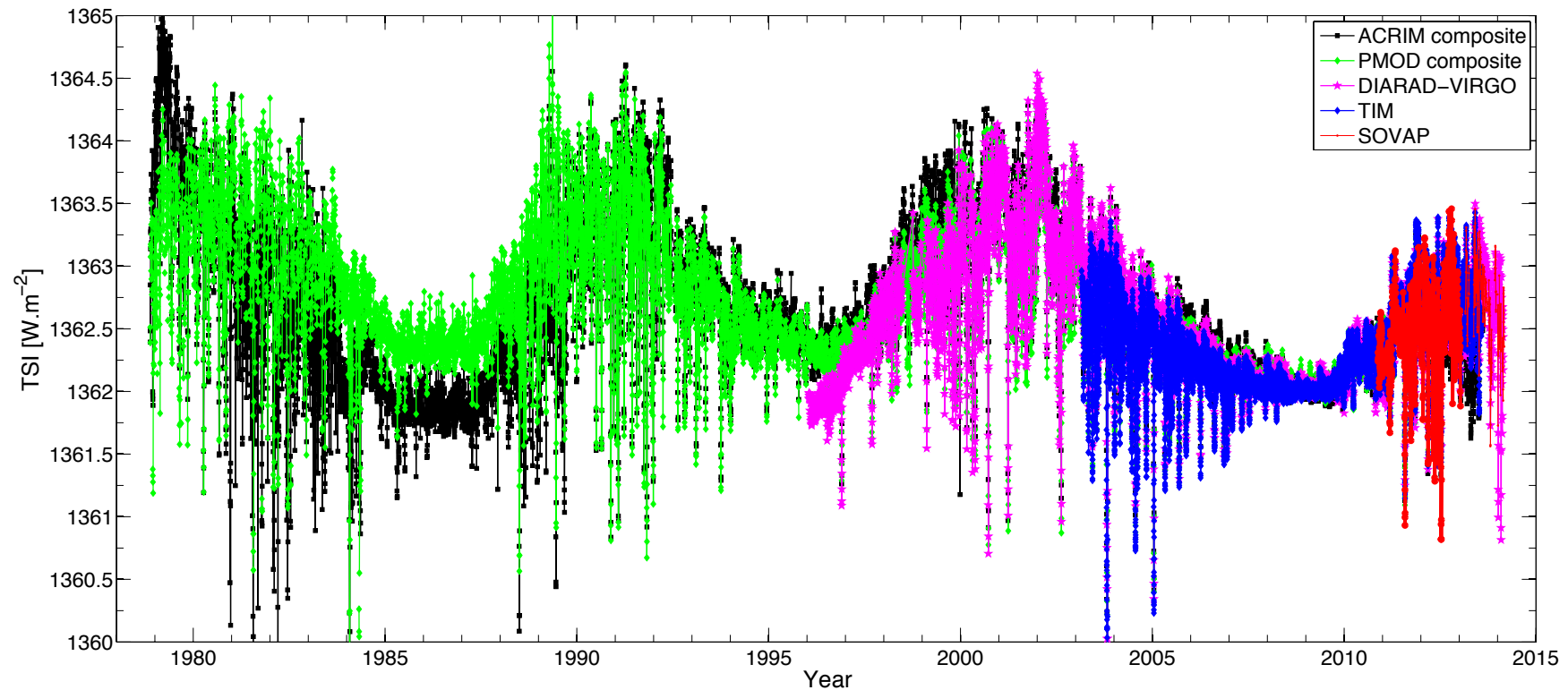

- The total solar irradiance (TSI) is measured to vary by approximately  $\pm 0.05\%$  (over the last three 11-year cycles).
- Composite TSI time series (ACRIM and PMOD) or TSI space instruments highlighting differences for some solar minima.

## 2<sup>nd</sup>: to improve TSI absolute value

Based on measurements collected from various spacecraft instruments over the last 35 years, the TSI has incrementally declined from 1371 W.m<sup>-2</sup> in 1978, to 1365 in the 1990's, and to around **1362 W.m<sup>-2</sup> in 2014.**

Instrument	Years	TSI	References
<b>ERB/NIMBUS 7</b>	<b>1978-1993</b>	<b>TSI ~ 1371 W.m<sup>-2</sup></b>	<b>Hickey et al., 1980 Hickey et al., 1988 Kyle et al., 1994</b>
ACRIM 1/SMM	1980-1989	TSI ~ 1367 W.m <sup>-2</sup>	Willson et al., 1981 (1368.31 W/m <sup>2</sup> )
ERBE/ERBS	1984-2003	TSI ~ 1365 W.m <sup>-2</sup>	Lee et al., 1987
ERBE/NOAA 9	1985-1989	TSI ~ 1364 W.m <sup>-2</sup>	Barkstrom et al., 1990
ERBE/NOAA 10	1986-1987	TSI ~ 1364 W.m <sup>-2</sup>	Barkstrom et al., 1990
ACRIM2/UARS	1991-2001	TSI ~ 1365 W.m <sup>-2</sup>	Willson & Mordvinov, 2001
SOVA 1/EURECA	1992-1993	TSI ~ 1365 W.m <sup>-2</sup>	Crommelynck et al., 1993
DIARAD/VIRGO on SOHO	1996-present	TSI ~ 1365 W.m <sup>-2</sup>	Dewitte et al., 2004
PMO6V/VIRGO on SOHO	1996-present	TSI ~ 1365 W.m <sup>-2</sup>	Finsterle et al., 2006 Fröhlich et al., 1997
ACRIM3/ACRIMSAT	2000-present	TSI ~ 1365 W.m <sup>-2</sup>	Willson & Helizon, 1999
TIM/SORCE	2003-2013	TSI ~ 1361 W.m <sup>-2</sup>	Kopp et al., 2005
PREMOS/PICARD	2010-present	TSI ~ 1361 W.m <sup>-2</sup>	Schmutz et al., 2013
<b>SOVAP/PICARD</b>	<b>2010-present</b>	<b>TSI ~ 1362 W.m<sup>-2</sup></b>	<b>Meftah et al., 2014 (Solar Phys.)</b>

# 3<sup>rd</sup>: to establish a radiation balance of the Earth

CERES EBAF Total-sky TOA LW ( $\text{W/m}^2$ )

January 5-year mean

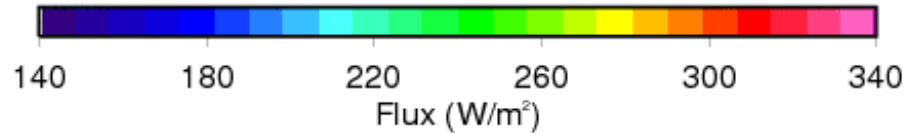
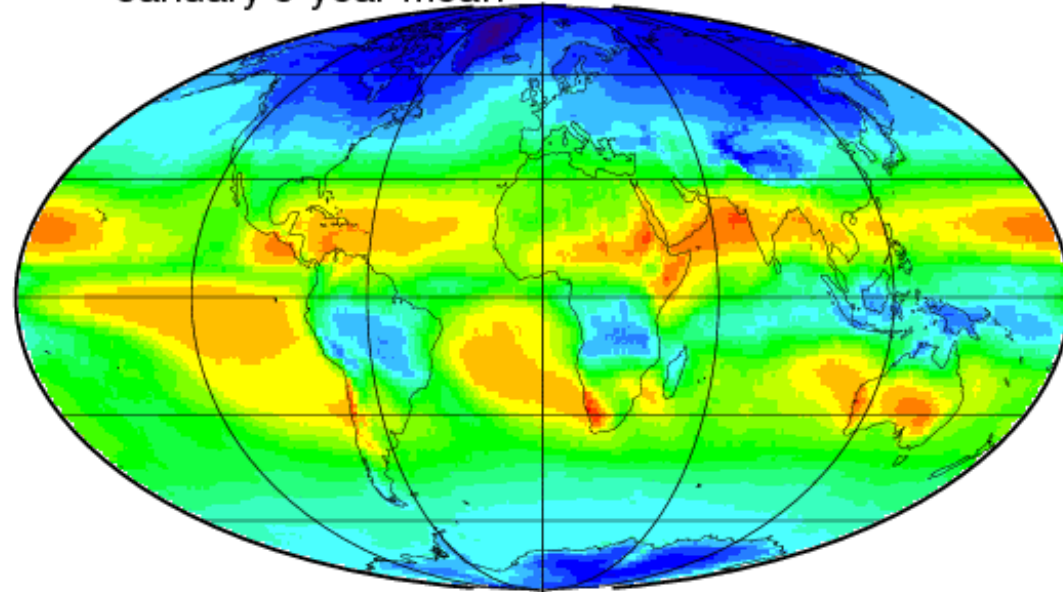
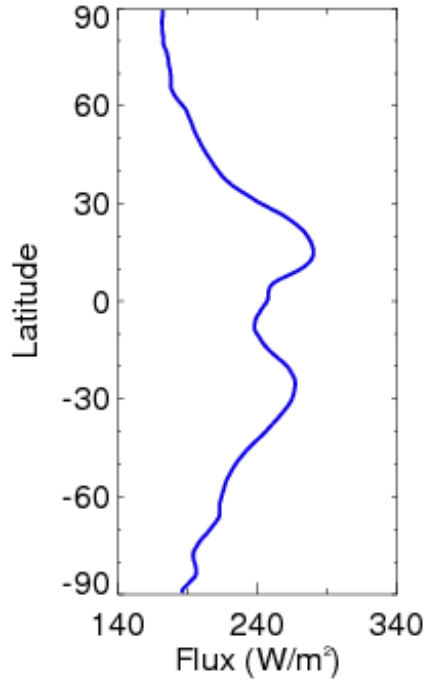

LW  
Global 236.53

- Determination of the Outgoing Longwave Radiation (OLR)
- Determination of the Reflected Solar Radiation or albedo flux



# 4<sup>th</sup>: to understand the relation between solar UV variability and stratospheric ozone

## Solar UV:

A direct measurement of the solar variability in the UV centered around 210 nm band will be realized. In the UV, the variation is more important over a solar cycle.

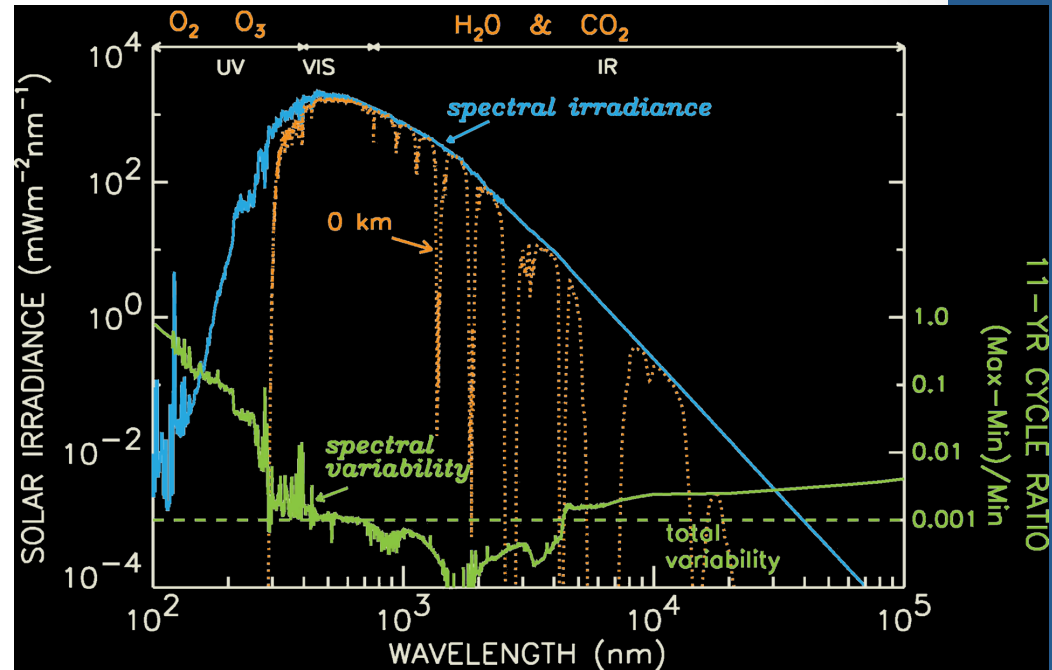

## Stratospheric Ozone:

The measurement of the vertical column of ozone is very important. In the stratosphere, the gas forms a layer around 20-40 km altitude that absorbs solar UV radiation.

A differential absorption measurement at two wavelengths (310 nm and 340 nm) will be realized.

## 2 – Planned schedule

- 2021: Satellite In Orbit Commissioning Review
- December 2020: Ready for flight
  
- January-September 2020: Satellite Assembling Integration & Test phase (AIT)
- January 2020: Payload delivery
- September 2018: Satellite Critical Design Review
- April 2018: Payload Critical Design Review
- October 2016: Payload Preliminary Design Review
- June 2016: Satellite Preliminary Design Review
  
- **2014-2015: Satellite and Payload preliminary design (Phase 0/A) → this is a Student program (X-CubeSat II)**

# 3 – SERB nanosatellite

The nano-satellite « to study the Sun and the Earth » is a three-unit “CubeSat”.

A preliminary configuration of the nano-satellite system can be seen below with deployable solar panels.

The key element of the mission is the space segment, containing the Nano-satellite (**10×10×33 cm<sup>3</sup>, 4.4kg maximum and 20.0 W maximum power budget**) that includes the payload and the avionics.

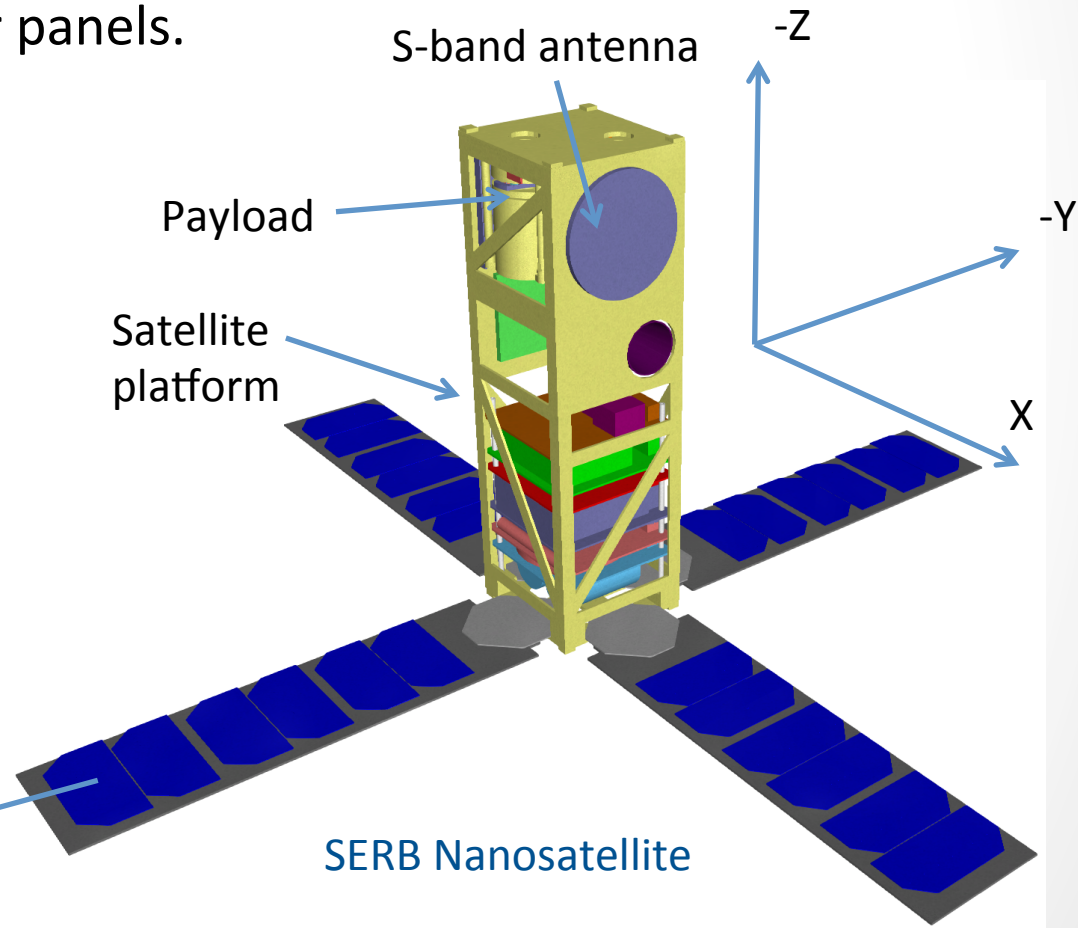

24 Azur Space solar cells

SERB Nanosatellite

# SERB (3D view)

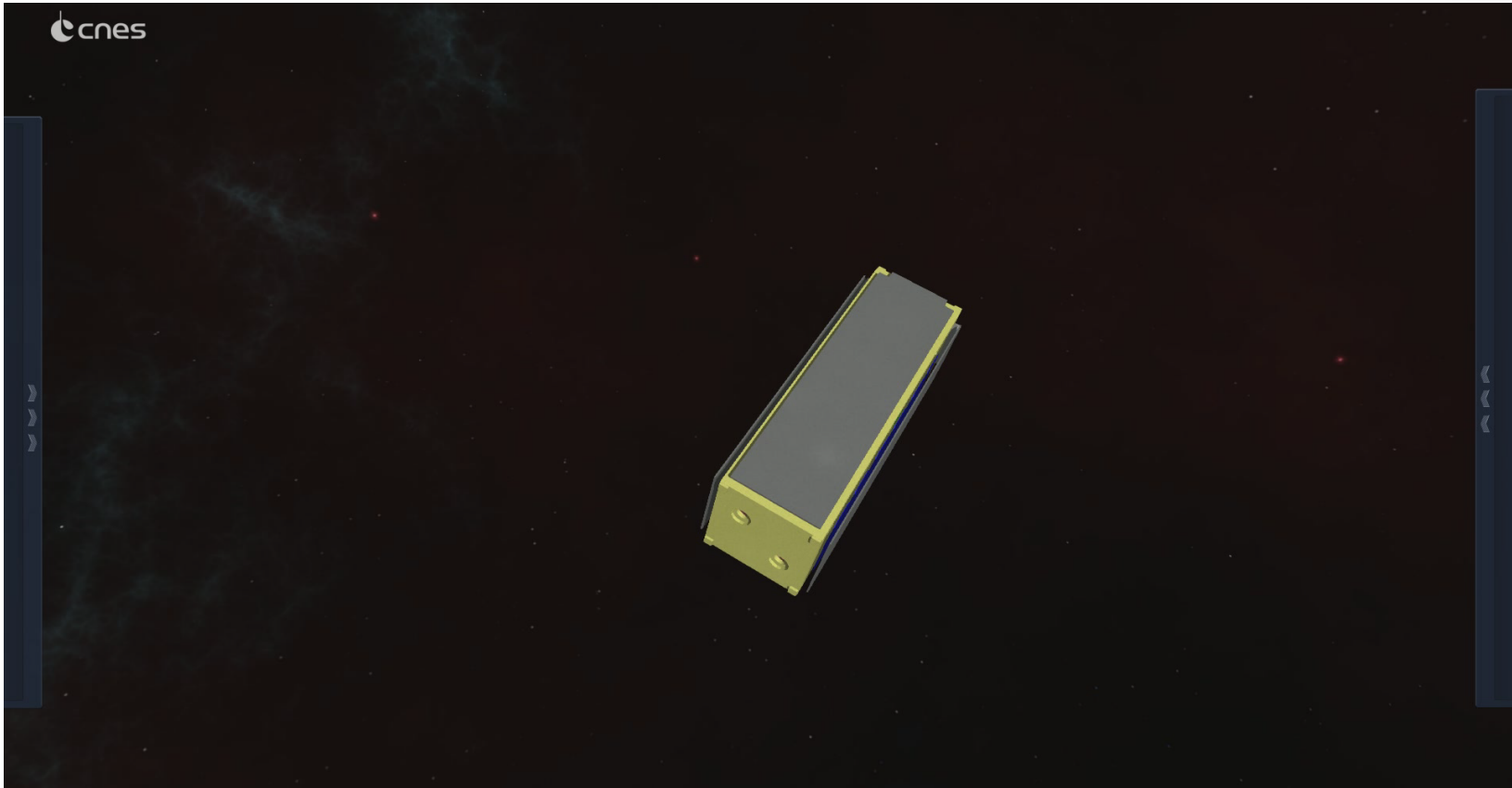

The key element of the mission is the space segment, containing the nanosatellite (**10×10×33 cm<sup>3</sup>**, **4.4kg maximum** and **20.0 W maximum power budget**) that includes the payload and the avionics.

# SERB (main characteristics)

This Table summarizes the main characteristics of the nano-satellite.

Parameter	Values (remarks)
Volume (un-deployed)	<b>10 (d) × 10 (w) × 33 (h) cm<sup>3</sup></b>
Mass	<b>4.4 kg</b> (maximum with a margin of 20%)
Power	<b>20 W</b> (without eclipses)
Field of view (payload)	180°
Data storage (flash)	128 Gbyte (with NINANO board)
Downlink speed (S-band option)	115.0 kbps - <b>8.0 Mbps</b>
Uplink speed (VHF)	1.2 kbps
Ground station contact time	< 14 minutes
Downlink volume (S-band option)	<b>0.4 Gbytes per day</b>
Uplink volume	0.3 Mbytes per day
Mission modes	Sun pointing, Nadir pointing, and stars pointing
Mission lifetime	<b>One year</b>

# SERB (mass repartition)

The interface displays a 3D model of the SERB satellite with a mass distribution color scale from 0 Kg (yellow) to 0.444 Kg (red). The current slider position is at 0%.

**EQUIPMENT SUMMARY**  
"NINANO"

RISK CHARACTERISATION **A**

MATURITY LEVEL **20 %**

**MASS**

Mass : **0.06 Kg**      Mass margin : **20 %**  
Mass incl. margin : **0.072 Kg**

**TEMPERATURES**

OP min : **-40 °C**      OP max : **50 °C**  
NOP min : **-40 °C**      NOP max : **50 °C**

**POWER**

Mode :

Power : -      Power margin : **20 %**  
Power incl. margin : -  
Power peak : **0 W**  
Dissipation : -  
Dissipation incl. margin : -

0 Kg      0.444 Kg  
0%

0:09

CONFIGURATION **Lancement**      VIEW MODE **Mass**      SATELLITE MODE

# SERB (exploded view)

cnes

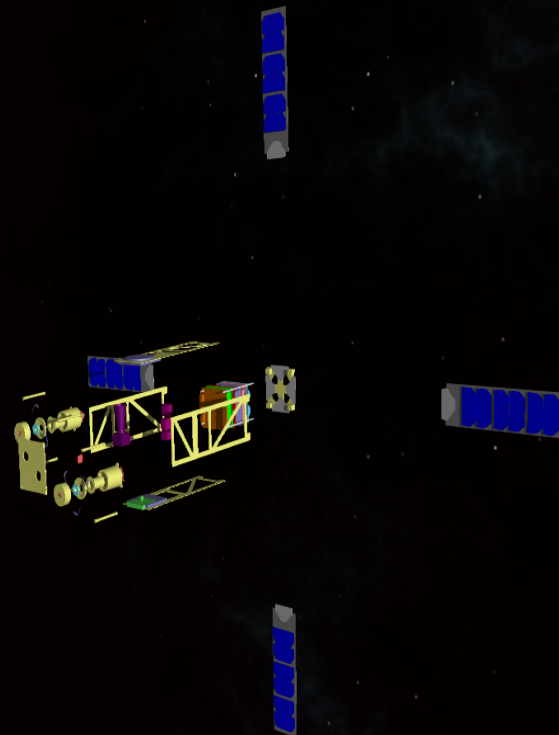

21%

CONFIGURATION

Lancement

VIEW MODE

Normal

SATELLITE MODE

# SERB (electronics)

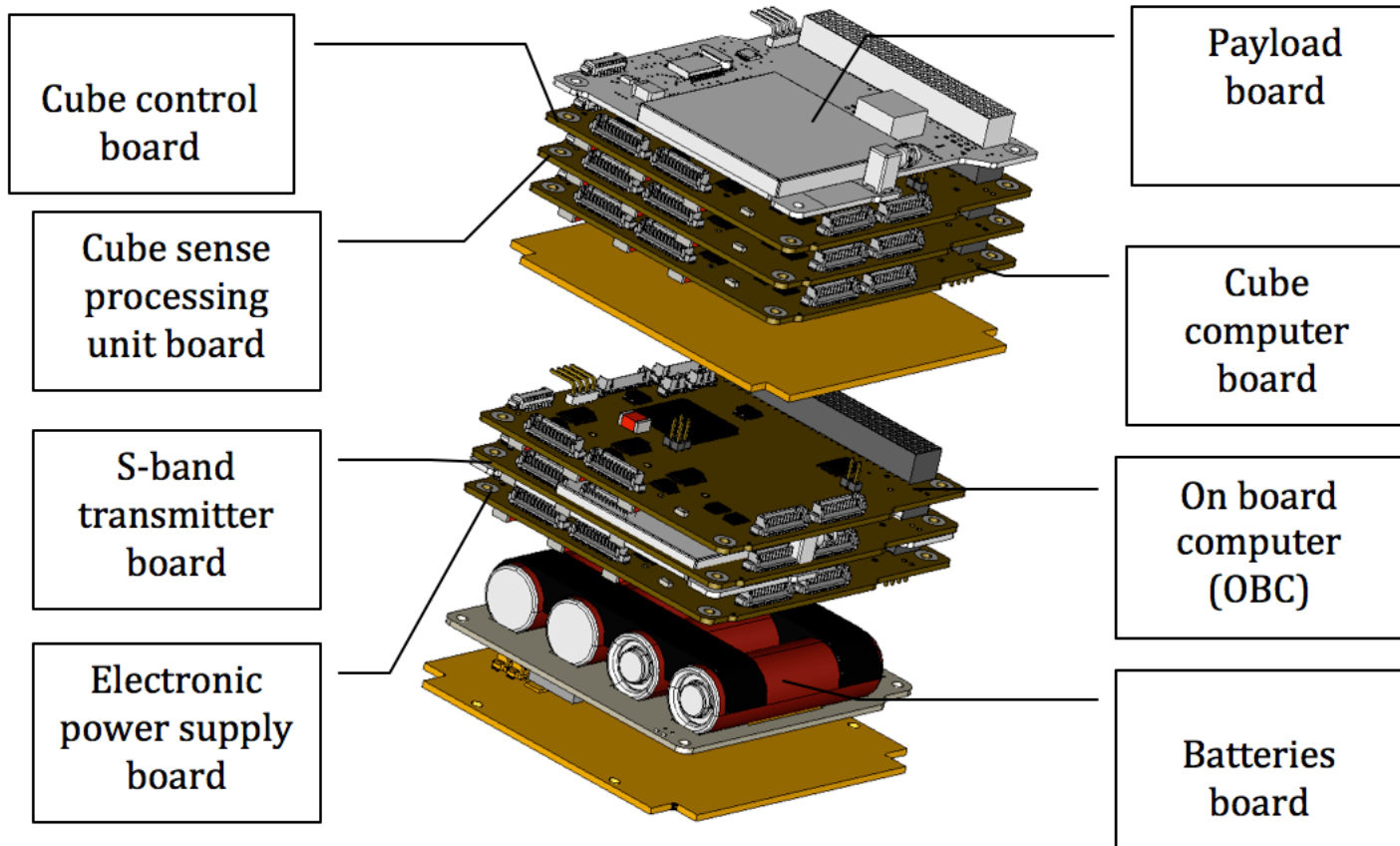

With radiation shielding.



# On-board computer and power boards

- On-board computer: use of the NINANO board (Steel, France)
  - 1 Gbyte DDR3 or 512Mbyte EDAC protected
  - 8 Kbyte FRAM
  - 16 Mbyte QSPI Flash for boot-loader and PL configuration
  - 128 Gbyte NAND flash for data storage
  - Ultrastable Crystal Oscillator XO
- Power (Steel Electronique, France):
  - 1 electronic board for Battery Charge Regulator (BCR) & 1 electronic board for Power Control and Distribution Unit (PCDU)
  - Different inputs to connect the Solar Generators
  - Battery charge management (Li-ion 4 cellules)
  - Thermal control management (heaters, temperature, etc.) & satellite deployment control
  - 3 regulated outputs 3V3/4W, 5V/13W, 12V/8W
  - 9 lines which can be controlled
  - TM / TC Management (temperature, voltage, current, power switch)

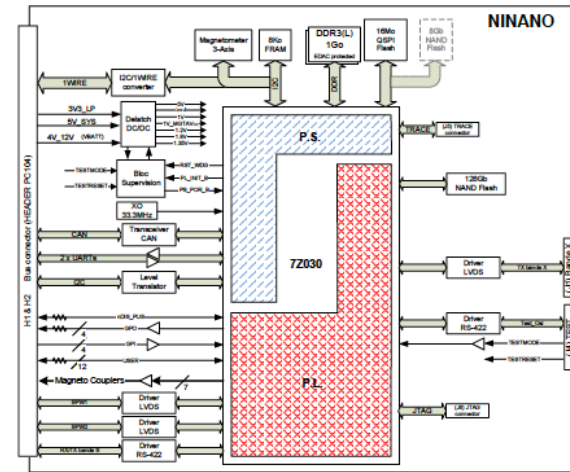

# S band transmitter/receiver: RF characteristics

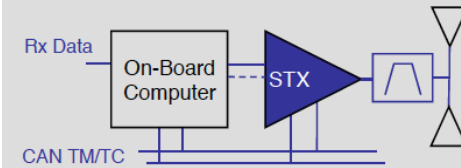

## For the satellite transmitter

- Frequency band: within the band 2200-2290 MHz
- RF Power from 27 to 33 dBm
- Data Rate: One fixed rate from 10 kbps to 3 Mbps
- Modulation: QPSK/OQPSK
- Convolutional Coding (7;1/2)
- Consumption: around 9.0 W for 2W RF output

- Mass: less than 400 g
- Dimensions without diplexer: 96 x 90 x 22,8 mm<sup>3</sup>
- Consumption : 10 W for 33 dBm RF output

## For the satellite receiver

- Frequency band: within the band 2025-2110 MHz
- Modulation: PCM/SP-L/PM
- Data Rate: One fixed rate selectable between at least 8, 16, 32, 64, 128, 256 kbps
- Maximum Doppler shift: +/-66kHz

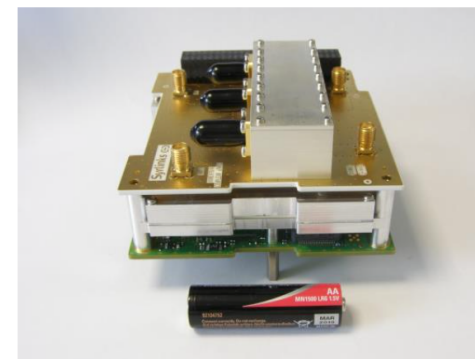

Views of the S band TT&C transponder with 2 diplexer configurations (credits: CNES).

# Pointing system electronic boards

The Stellanbosh/Surrey Space Centre ADCS (**Attitude Determination and Control system**) will provide attitude sensing and control capabilities to SERB nanosatellite in order to meet the system requirements and science unit requirements.

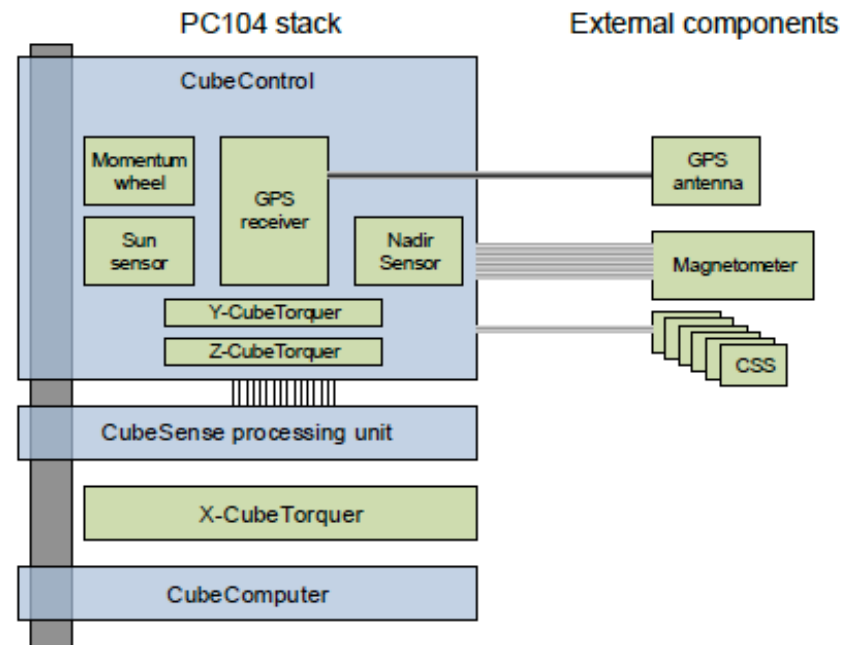
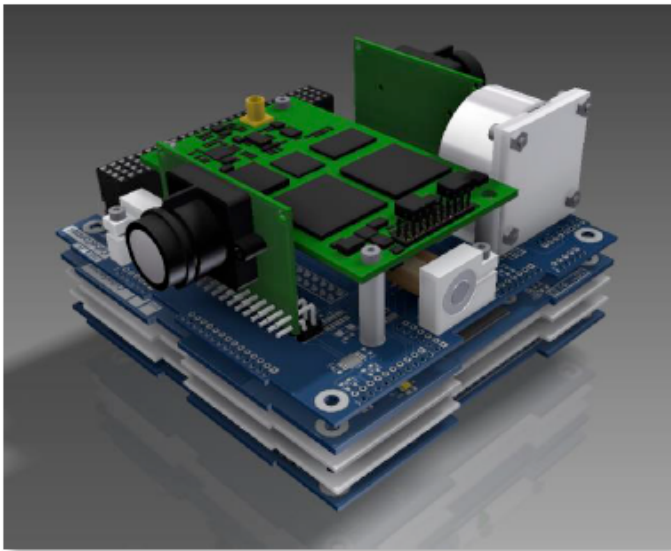

The desired performances are:

Sun pointing: the platform is three-axes stabilized. The **attitude and orbit control subsystem (AOCS)** is required to provide a pointing accuracy of  $0.1^\circ$ .

Nadir pointing: the ARM-SAT satellite is pointed towards the Earth (payload line of sight) with accuracy better than  $1^\circ$ . There is also a GPS.

# SERB operating modes

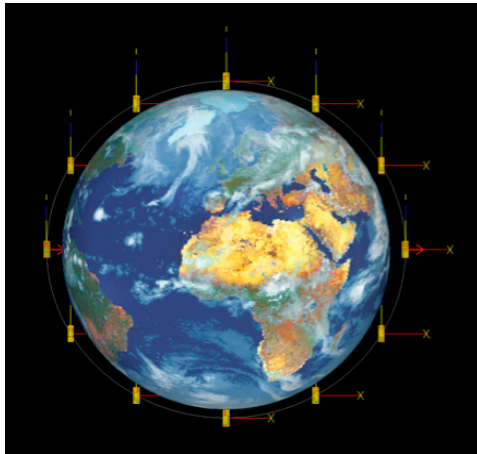
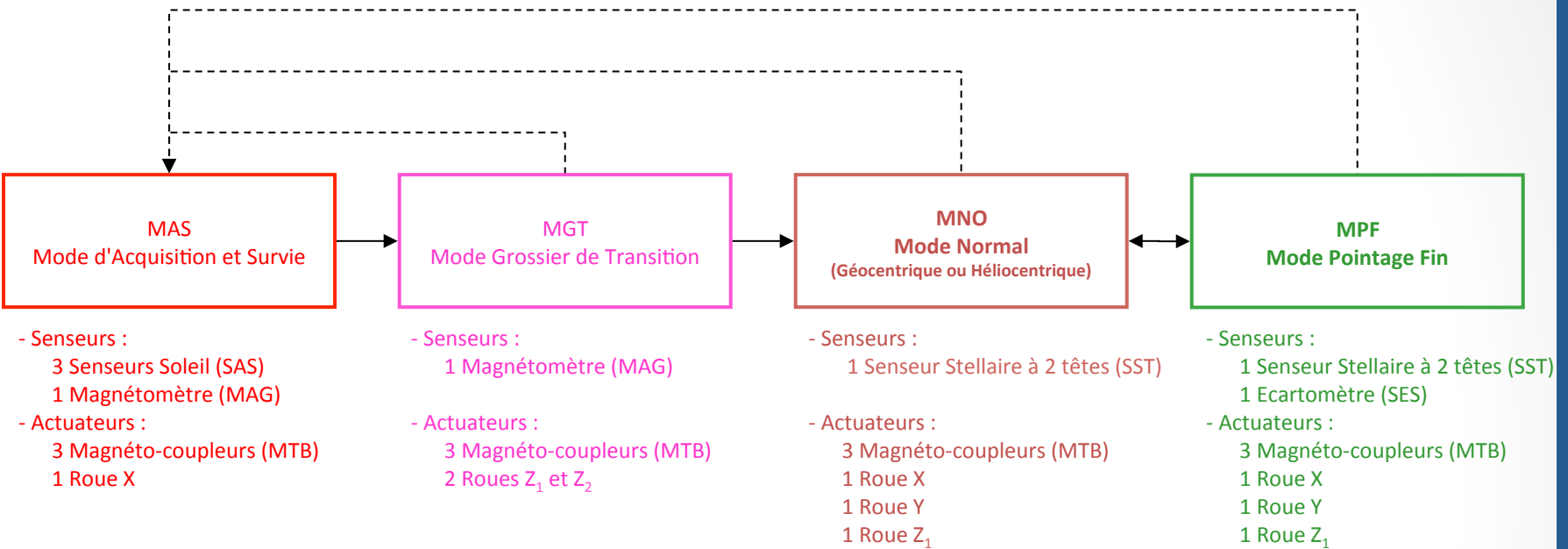

« P-Sun » → **MPF** mode

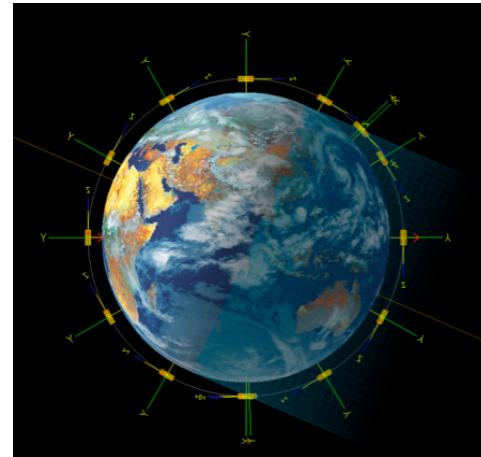

« P-Nadir » → Direct observation of the Earth (activity of the O3): **MNO**

# SERB (launch vehicle and orbit)

- Launch schedule:  
2020-2021

- Launch Vehicle:  
To be define

- Target Orbit:

- Helio-synchronous Orbit

- Altitude: 680 +/-30 km

- Local time at ascending node:  
06H00 +/-00H30

- Orbital inclination: 98.21 +/-0.

Life time: ~ 12 months

**Objectives: constellation**

**Next step: L1 orbit (Solar Physics)**

Debris mitigation guidelines and the preservation of the space environment

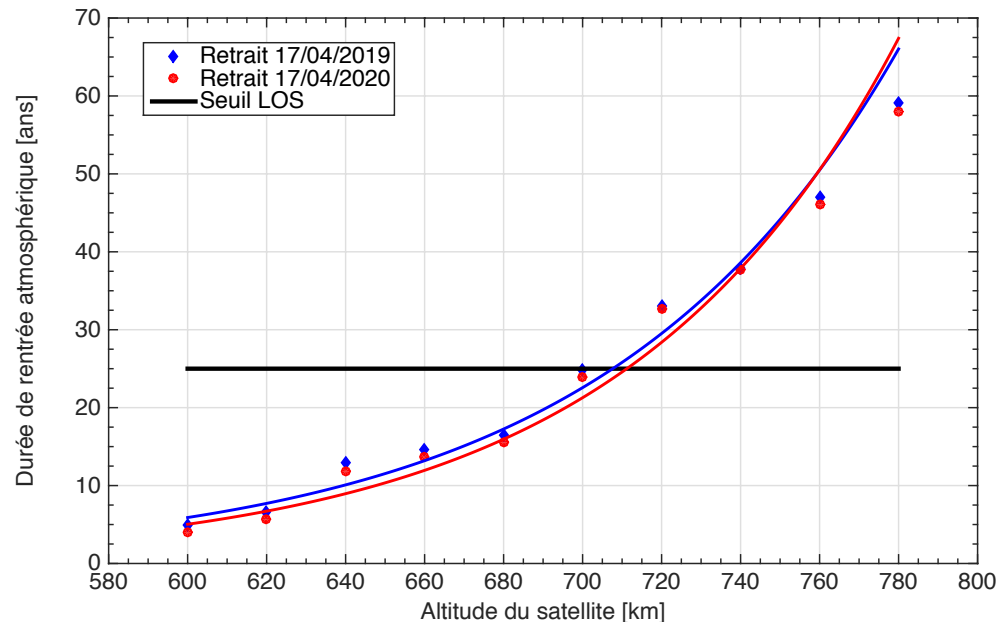

LOS : loi des opérations spéciales

# 4 – SERB payload

The payload encompasses four instruments in a 1 kg, 10 10 10 cm<sup>3</sup> space, and requires 1W of power. Instruments are:

- a solar radiometer (SR) of new instrumental design, used for the measurement of the total solar irradiance;
- two Earth radiometers (ER1 and ER2) which measure the IR radiation and the albedo;
- a UV sensor (UVS) detector for the solar radiations Herzberg continuum between 200 and 220 nm;
- And a camera

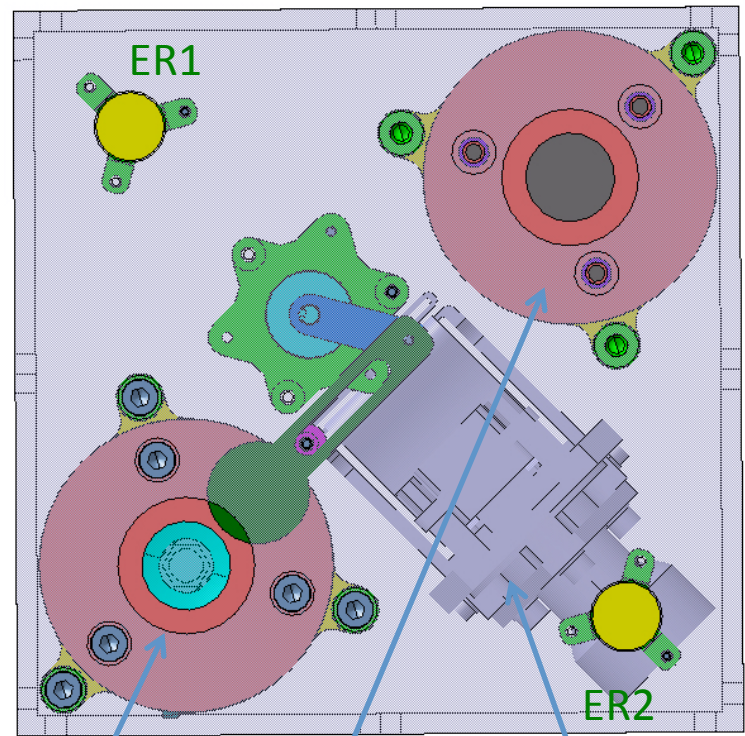

A solar radiometer  
A UV photometer  
A camera

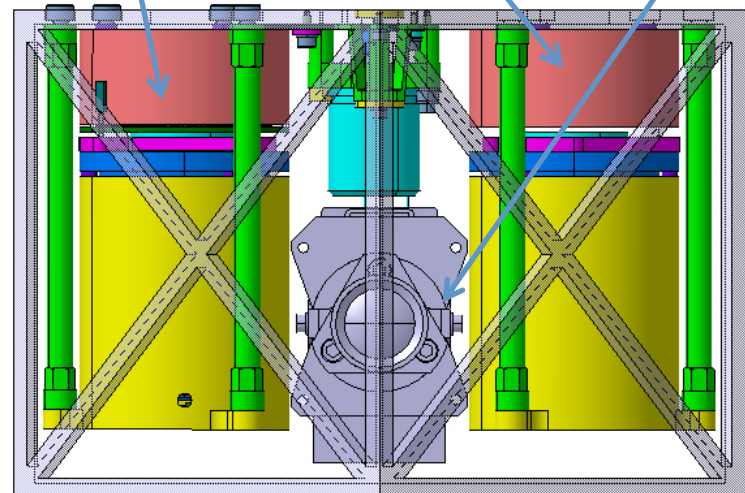

# SERB payload (2D representation)

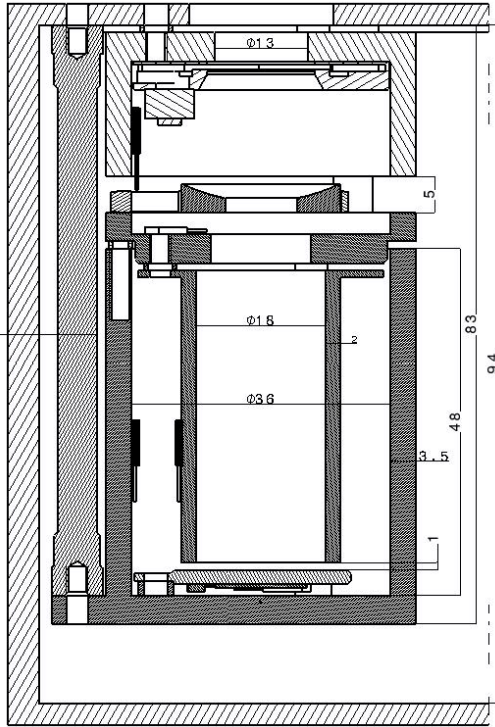

## Solar radiometer

A solar radiometer covers the spectral range 0.2 to  $3\mu\text{m}$ .

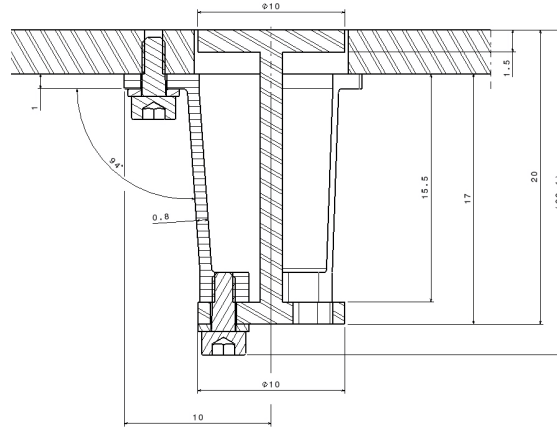

## IR & albedo sensors

A simple two-radiation plate system (structure element with white paint and black paint), covering 0.1 to  $100\mu\text{m}$  spectral range.

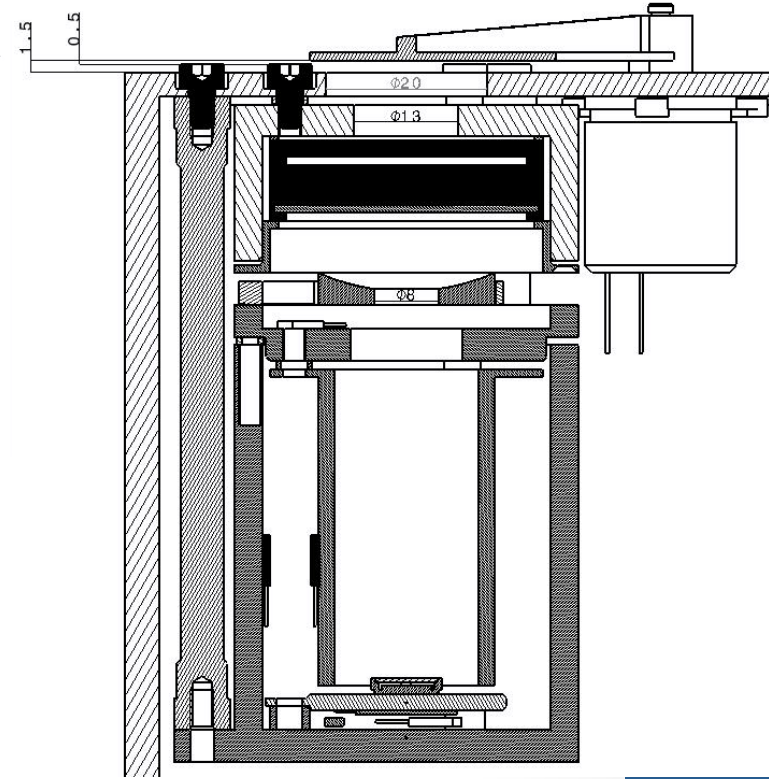

## UV photometer

A UV photometer covers the spectral range between 200 and 220 nm. Use of a typical interferential filter.

# SERB payload (3D representation)

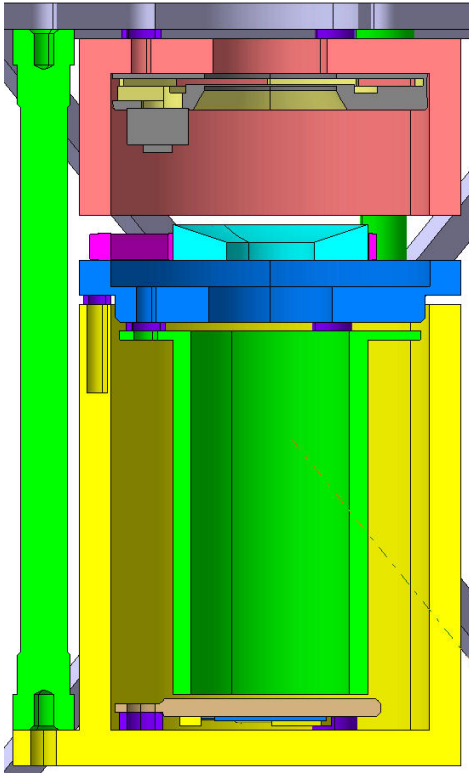

Solar radiometer

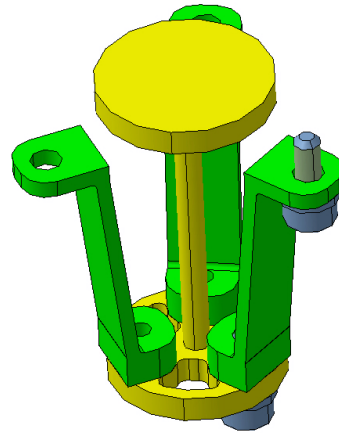

IR & albedo sensors



Camera

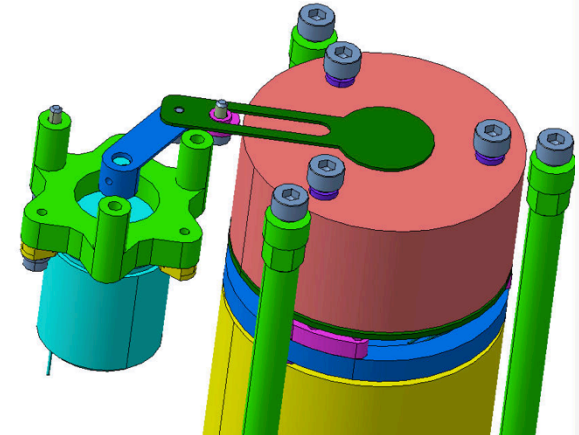
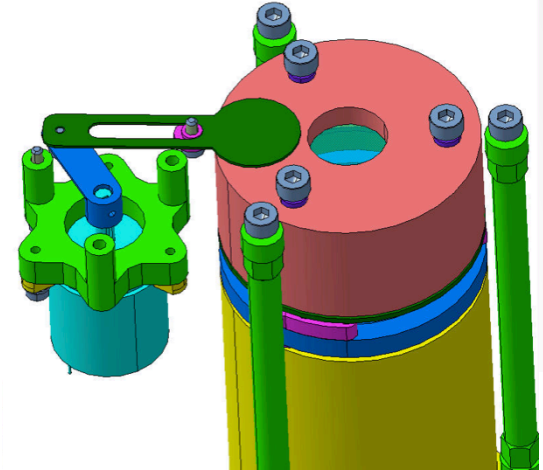

UV photometer



# SERB thermal model

A preliminary thermal mathematical model was developed to study temperature variations and thermal gradients affecting the nano-satellite in different typical cases in orbit (summer solstice, hot case in February and winter solstice).

The ultimate goal of this thermal analysis is to ensure that all the components of the nano-satellite will be functioning in their safe range of temperatures and with a proper heat rejection.

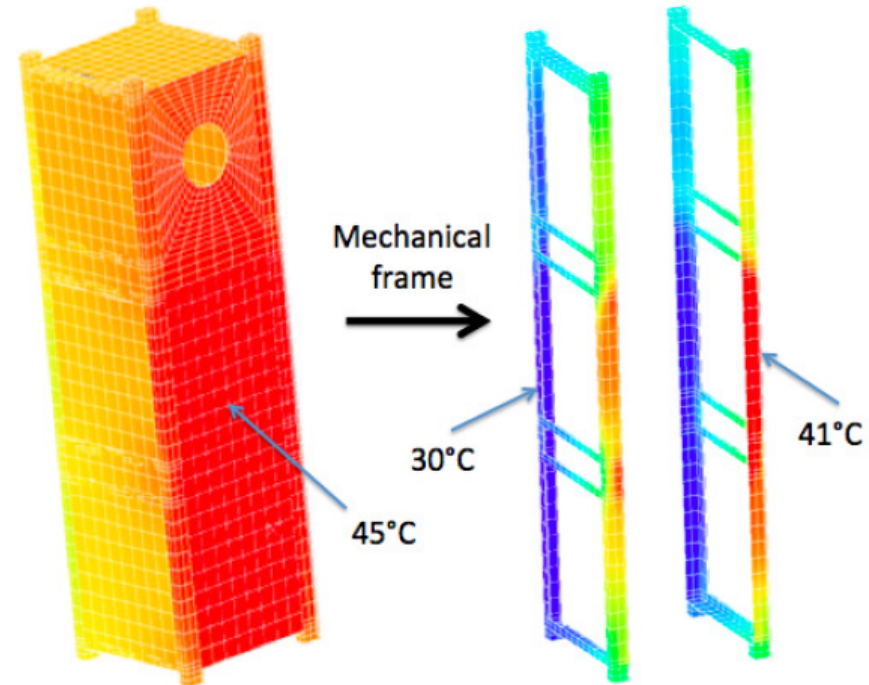
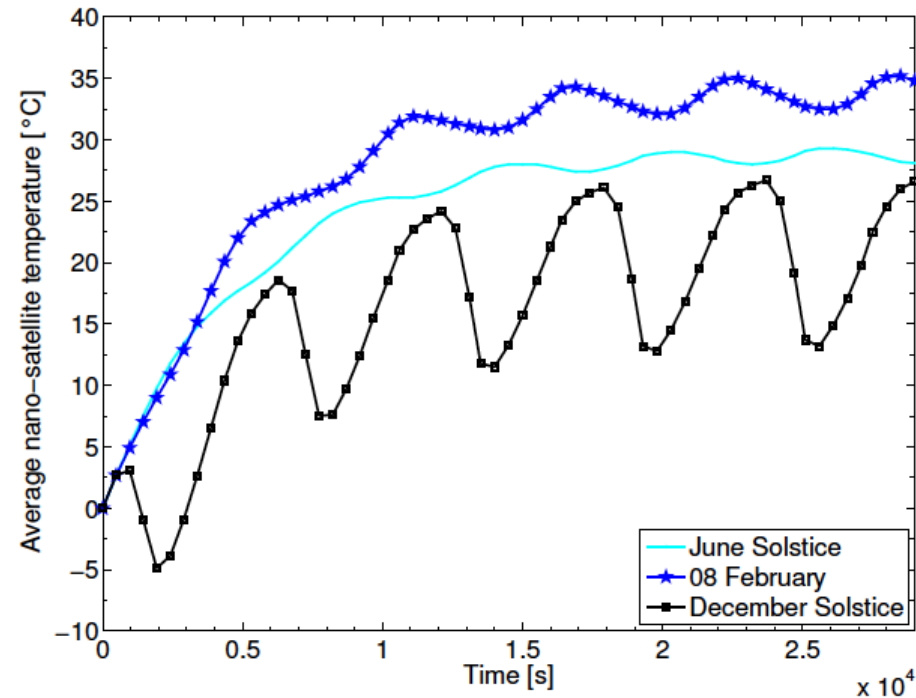

# SERB mechanical model

Some preliminary mechanical analyses have been carried out on the nano-satellite. Indeed, models were needed to design the nano-satellite and to give the accelerations' envelope on the payload instruments interfaces.

The first Eigen frequency of the structure is at 191.7 Hz (local board mode along X-axis). The first global mode of the structure is at 499.8 Hz (see the Figure).

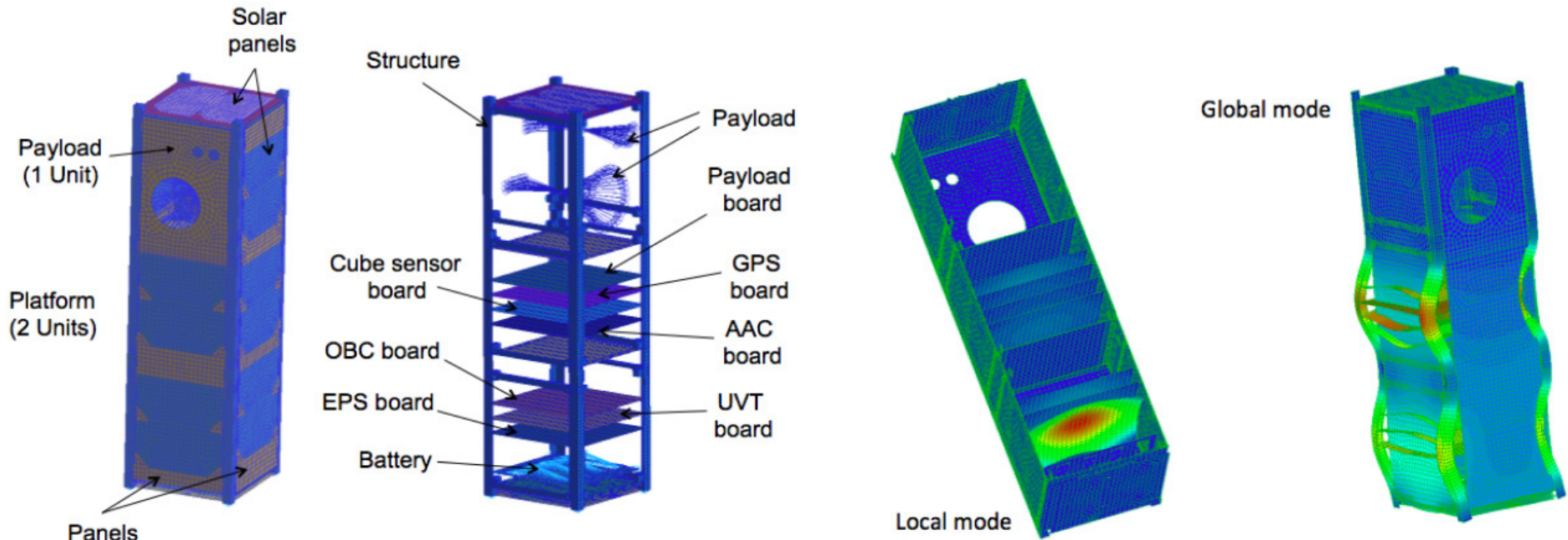

# SERB requirements

## Mechanical test

Model	Qualification	Acceptance
Direction	X, Y and Z	X, Y and Z
Rms acceleration	8.0 g rms	6.5 g rms
Duration	120 s	60 s
Profile	20 Hz - $0.009 \text{ g}^2 \cdot \text{Hz}^{-1}$ 130 Hz - $0.046 \text{ g}^2 \cdot \text{Hz}^{-1}$ 800 Hz - $0.046 \text{ g}^2 \cdot \text{Hz}^{-1}$ 2000 Hz - $0.015 \text{ g}^2 \cdot \text{Hz}^{-1}$	20 Hz - $0.007 \text{ g}^2 \cdot \text{Hz}^{-1}$ 50 Hz - $0.007 \text{ g}^2 \cdot \text{Hz}^{-1}$ 200 Hz - $0.035 \text{ g}^2 \cdot \text{Hz}^{-1}$ 640 Hz - $0.035 \text{ g}^2 \cdot \text{Hz}^{-1}$ 2000 Hz - $0.010 \text{ g}^2 \cdot \text{Hz}^{-1}$

## Thermal test

Model	Qualification	Acceptance
Maximum non operational temperature	+65°C	+60°C
Maximum Switch-On Temperature	Not applicable	Not applicable
Maximum operational temperature	+60°C	+50°C
Minimum operational temperature	-35°C	-25°C
Minimum Switch-On Temperature	-40°C	-40°C
Minimum non operational temperature	-50°C	-50°C
Number of cycles	8	4
Dwell time	3 hours	3 hours
Temperature Rate of Change	>2°C per minute	>2°C per minute
Pressure	<10 <sup>-5</sup> mbar	<10 <sup>-5</sup> mbar

# CNRS LATMOS facilities



Cleanroom for integration (particularly for UV filters)

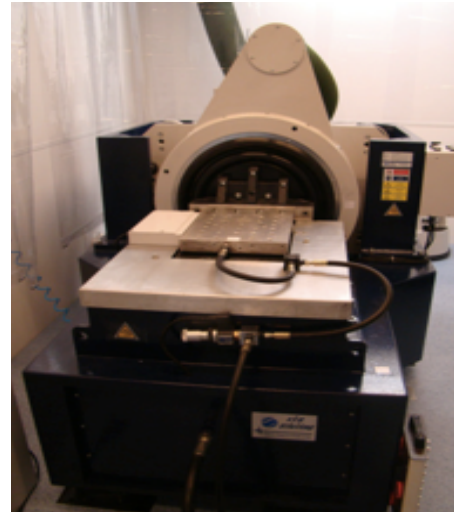

Mechanical tests (random) with CNRS-LATMOS facilities



# 5 – Ground segment: S band antenna

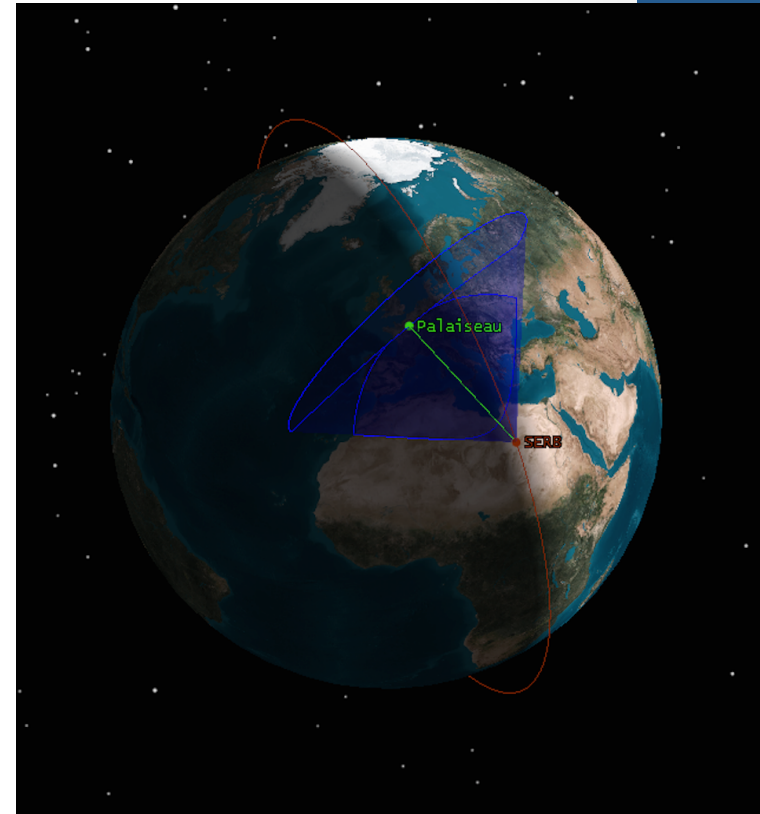

## → Main characteristics of the antenna

- Antenna of 2.4 m diameter
- Frequency (Rx): 2200-2300 MHz
- Frequency (Tx): 2015-2120 MHz
- Efficiency: 55%
- Gain (back-lobe gain): -30 dB
- Debit: around 5 Mbit per second

# S-band antenna

## Station visibility: Palaiseau or Toulouse (France) vs. SERB

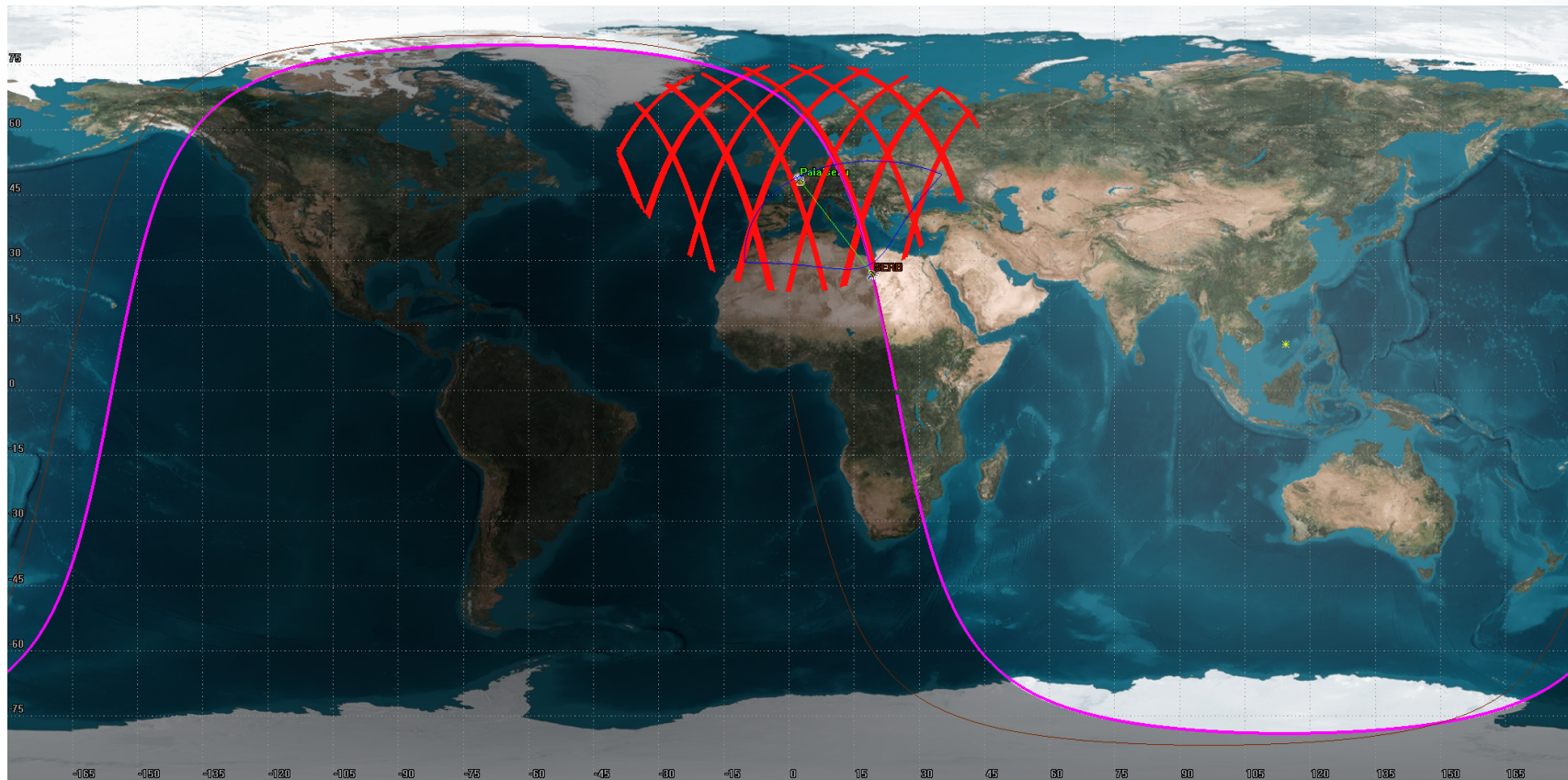

→ STK use

# Conclusions

The role of nano-satellites for education is well established.

Space sciences remain very attractive for young people interested in new technologies.

Nano-satellites provide an appealing way for training students to space activities and more generally to complex technological projects, from fundamental and engineering sciences to project management and communication.

Critical components of instrumental payloads of future large missions can acquire the technical maturity by flying in a CubeSat (coatings, UV filters, etc. ).

Nano-satellites represent also an excellent alternative of instrumentation testing, providing longer flights than rockets.

**Even now, targeted science can be performed by nano-satellites.**

In summary, we are promoting the development of one or several nano-satellites, to extend TSI variability measurement, to improve the knowledge of the absolute value of the TSI, to establish a radiation balance of the Earth with an accuracy better than 5% and to understand the relation between solar ultraviolet variability and stratospheric ozone. L1 orbit is more interesting for Solar Physics application (UV variability).