



PIXE 2015: PocketSpacecraft.com Integrated exploration Environment update

Michael Johnson
michael@PocketSpacecraft.com

4th Interplanetary CubeSat Workshop
iCubeSat 2015

London, United Kingdom
26th May 2015

- Founded 2010
- Ops in China, IoM, UK & USA
- Creates, encourages, funds, manages or otherwise supports more than two dozen open source open access space exploration infrastructure projects
- Seven flight projects
- Collaborate with academia, enthusiasts, government, industry and non-profits
- >300 volunteers, >30 countries

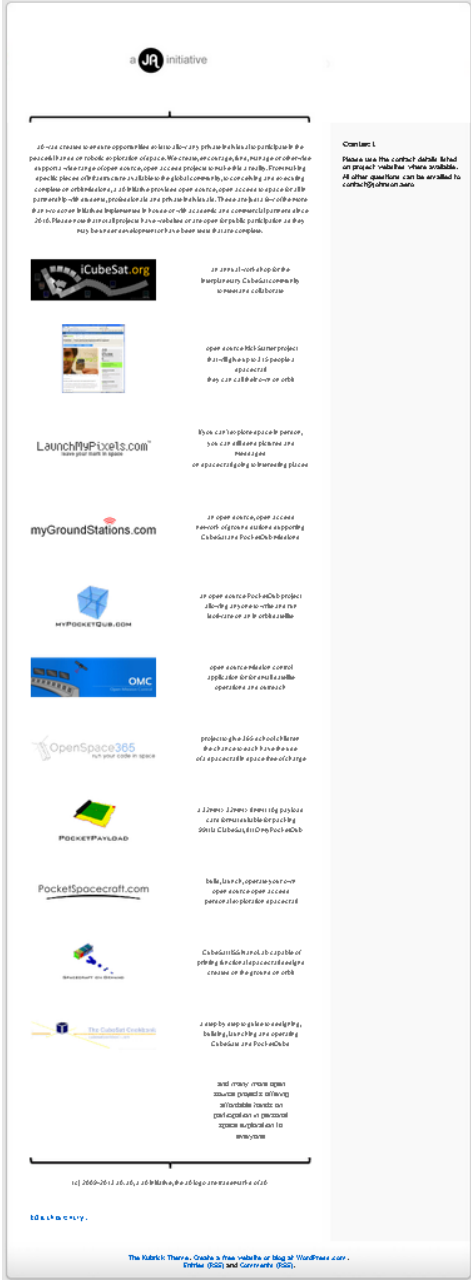

goal

send spacecraft to orbit and/or land on
the surface of every body in the solar
system over the next ~~25~~ 21.1 years

goal

send spacecraft to orbit and/or land on the surface of **every** body in the solar system over the next ~~25~~ 21.1 years

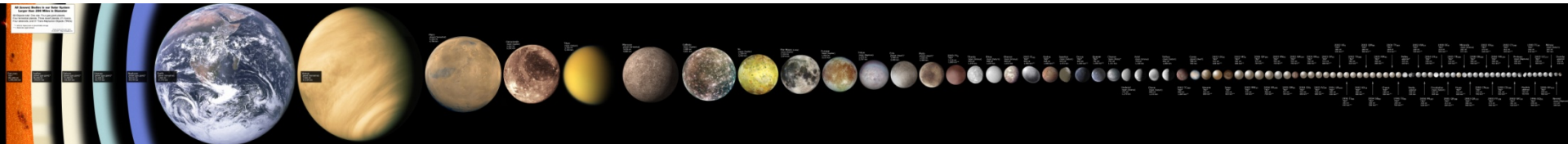

$>10^1 > \sim 5000\text{km}$ radius

$>10^2 > \sim 100$ km radius

$>10^4 > \sim 20$ km radius

$>10^6 > \sim 0.5\text{km}$ radius in asteroid belt alone

pocket spacecraft

a spacecraft that an individual can afford to buy, launch and operate with little or no technical expertise



personal space age

the era of exploration of space by private individuals for science, general interest and profit



- science goals
 - be useful, be responsible
 - work within existing frameworks and systems where possible
 - enable many of the >95% of missions not down selected
- consumer goals
 - support 10^6 participating explorers
 - video game size quantum of exploration
 - instant gratification and mass customisation
 - appeal to everyone from collectors to citizen space engineers
- easy to use for everyone
 - point and click/touch design, collaboration and autonomous operation
- sustainable
 - fun, interactive, immersive for years or decades
 - spread risk, be comfortable not knowing where it may lead
 - legal, honest, decent and truthful
 - make affordable - crowd source, fractionate and automate everything
- symbiotic and respectful
 - scientists need explorers, explorers need scientists
 - everyone needs engineers
 - all skill levels can contribute something – apps/money both ways

- Crowd sourced funding via 315 KickStarter backers
 - 67 @ \$25
 - 67 @ \$75
 - 88 @ \$300 ←
 - 26 @ \$1000 ←
 - 0 @ \$5000
 - 1 @ \$10000
- NASA ELaNa 5 launch April 2014
- Student labour
- Reuse existing open source systems
- Very inexpensive
- Very short lived

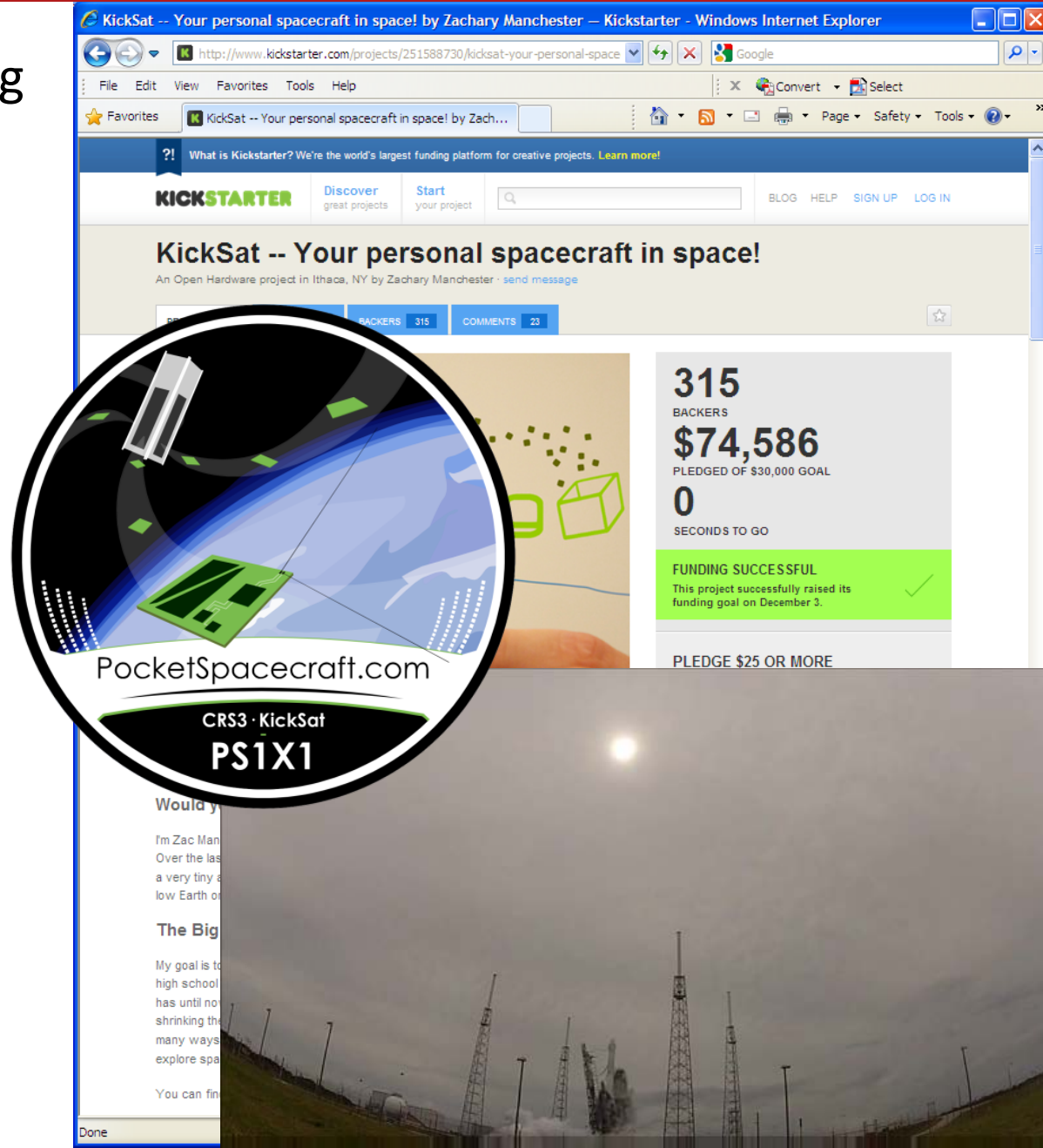

KickSat -- Your personal spacecraft in space! by Zachary Manchester — Kickstarter - Windows Internet Explorer

http://www.kickstarter.com/projects/251588730/kicksat-your-personal-space

KICKSTARTER Discover great projects Start your project

KickSat -- Your personal spacecraft in space!
An Open Hardware project in Ithaca, NY by Zachary Manchester · send message

BACKERS 315 COMMENTS 23

315 BACKERS
\$74,586
PLEGGED OF \$30,000 GOAL
0 SECONDS TO GO

FUNDING SUCCESSFUL
This project successfully raised its funding goal on December 3.

PLEDGE \$25 OR MORE

PocketSpacecraft.com
CRS3 · KickSat
PS1X1

Would you like to back this project?
I'm Zac Manchester
Over the last few years I've been working on a very tiny satellite in low Earth orbit.

The Big Picture
My goal is to launch a satellite from a high school in Ithaca, NY. I've been shrinking the size of the satellite in many ways to explore space.

You can find out more about the project here.

Done

Pocket Spacecraft

TF-SLR Scout prototype v0.4

Solar cell
CIGS or Spectrolab TASC

SoC lapped to <math><50\mu\text{m}</math>
TI CC430F5137IRGZ die

Printed passives (RCL)
e.g. Cabot CCI-300 ink

Antenna bustle/actuator
NiTi memory metal

Custom graphics
Laser marked

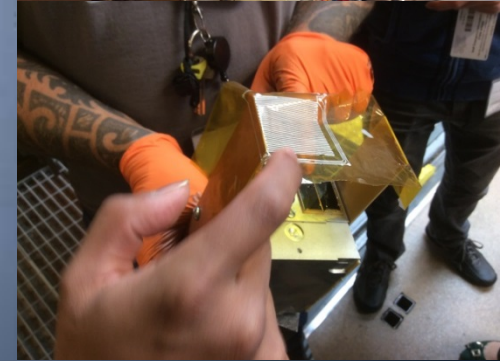



Resistance:

- ‘They will never work’
- ‘You can’t do anything useful’
- ‘They are just for students’
- ‘You can’t do real science’
- ‘You can’t fit real instruments’
- ‘You can’t do useful imaging with such small apertures’
- ‘They don’t have enough power’
- ‘They’re unreliable’



It's hard to imagine [ChipSats and TF-SLRs] will be capable enough

Resistance:

- ‘They will never work’
- ‘You can’t do anything useful’
- ‘They are just for students’
- ‘You can’t do real science’
- ‘You can’t fit real instruments’
- ‘You can’t do useful imaging with such small apertures’
- ‘They don’t have enough power’
- ‘They’re unreliable’

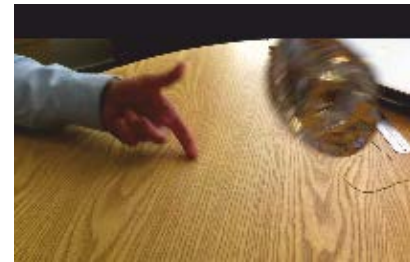



“It’s hard to imagine [ChipSats and TF-SLRs] will be capable enough, but that’s exactly what people said about CubeSats.”

*Therese Moretto Jorgensen, Program Director, National Science Foundation
Nature **508**, 300-301 (17 April 2014)*

PocketSpacecraft.com

LOFAR Configuration
 Observation: PS86X1/O2
 Start: T+93:00:00.00
 Duration: 00:10:12.00
 Channel(s): 235
 Centre: 145.8984375 MHz
 Mode: Complex Voltage
 Sub-mode: Fly's eye
 Reference: 20141019/7.1.7.3.19

-  Antenna
-  Network link
-  Data centre

SE607HBA - Onsala
 3370272.092, 712125.596, 5349990.854
 57.39875746, 11.93085904, 41.358
 Delay compensation: OFF

CS002LBA - Superterp
 3826577.462, 461022.624, 5064992.526
 52.91511897, 6.86983284, 49.350
 Delay compensation: ON

DE604HBA - Potsdam-Bornim
 3796380.254, 877613.809, 5032712.272
 52.43785922, 13.01648194, 75.843
 Delay compensation: OFF

AMS-IX - Amsterdam

PS-DC44A - Bristol

DE605HBA - Jülich
 4005681.407, 450968.304, 4926457.940
 52.91511897, 6.86983284, 49.350
 Delay compensation: OFF

UK608HBA - Chilbolton
 4008462.280, -100376.948, 4943716.600
 51.14354266, -1.43445876, 177.05
 Delay compensation: OFF

DE603HBA - Tautenburg
 3940296.126, 816722.532, 4932394.152
 50.97939457, 11.71012829, 376.426
 Delay compensation: OFF

DE601HBA - Effelsberg
 4034101.901, 487012.401, 4900230.210
 50.52260408, 6.88365595, 365.993
 Delay compensation: OFF

FR606HBA - Nançay
 4324017.054, 165545.160, 4670271.072
 47.37552429, 2.19250034, 182.091
 Delay compensation: OFF

DE602HBA - Unterweilenbach/Garching
 4152568.416, 828788.802, 4754361.926
 50.97934787, 11.71126745, 378.840
 Delay compensation: OFF

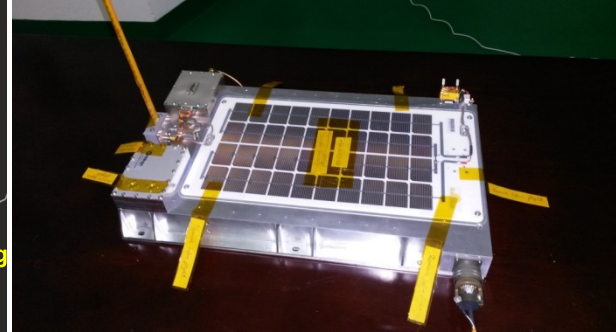
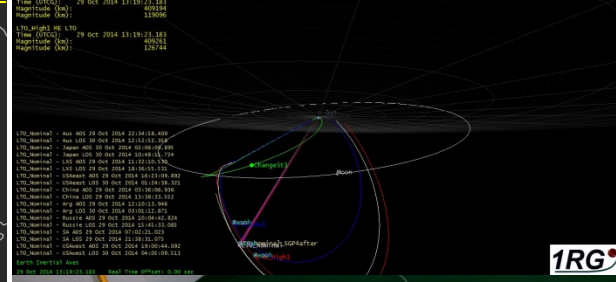

Graphics courtesy: ASTRON, JA, LuxSpace, STFC

- Planetary protection (to Category IVc)
- Spacecraft can be launched speculatively
- Potential clashes with existing frameworks (e.g. amateur vs scientific vs commercial)

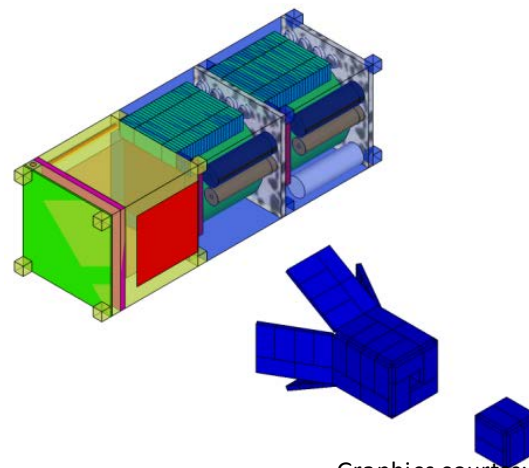
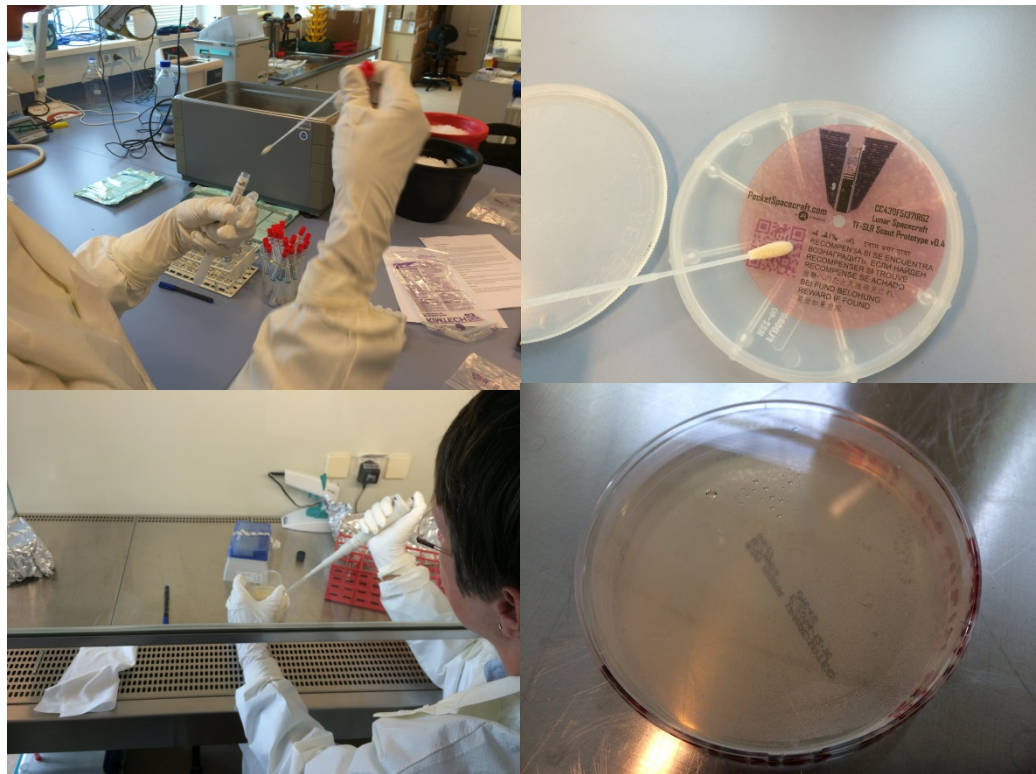

- 3881 payloads catalogued on orbit by U.S. Space Surveillance Network
- KickSat proof of concept low earth orbit mission launched 2014: >100 spacecraft
- Pocket Spacecraft interplanetary proof of concept mission 2015/16: >1000 spacecraft
- Potentially >1 million TF-SLRs to come over next two decades
- Number of spacecraft printed per mothership may be unknown at launch and could vary by orders of magnitude

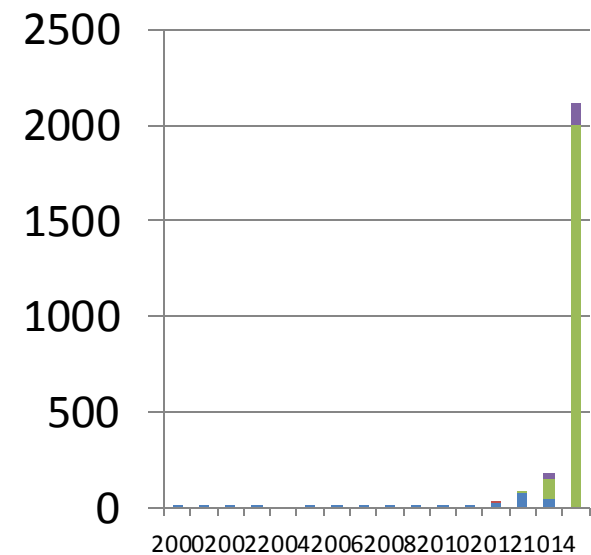

- Current regulatory fees for spacecraft that can profitably be manufactured, launched and operated for less than \$99 each can be disproportionate (>\$10,000 per spacecraft)
- License application fee (no guarantee of success):
UK: £6,500- £13,000 per mission (£0 in China, Spain, USA, etc.)
- €60 million third party insurance cover per mission:
UK: €600,000 per year indefinitely (£0 in China, Spain, USA, etc.)



- Pocket Spacecraft interplanetary proof of concept mission has spacecraft backed by participants from >40 countries
- Spacecraft could be designed, manufactured, launched, deployed, managed or operated by different children and adults with multiple citizenships with ownership changing at every step and over time



Where do you want to explore today?

michael@PocketSpacecraft.com
@mySpacecraft

- * if your question is about an open source project:
 - no restrictions
- * if your question is about a closed source project and we're at JPL:
 - please be aware that there is no export license for this activity. This visit request is approved by I/ECO provided that no export controlled technical data or technical assistance related to a spacecraft or its systems / subsystems will be provided by JPL. All export controlled technical data in office areas that the visitor(s) is to visit must be removed from sight either behind closed doors that will not be visited or in closed files. All discussions, presentations, and/or information released to the foreign visitor must not contain export controlled technical data. Information released must be limited to general descriptions and information already published in the public domain. Technical discussions must not disclose design, development, production, manufacture, assembly, operation, repair, testing, maintenance or modification of any defense articles (e.g. spacecraft or instrument). Escorted areas where access is granted to the foreign visitor(s) may not contain exposed export controlled technical information. Please contact I/ECO if further guidance is desired.

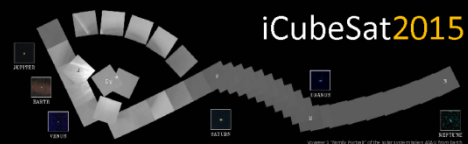

4th Interplanetary CubeSat Workshop
South Kensington, London, United Kingdom
26-27 May 2015

KubeSat 2015, the fourth Interplanetary CubeSat Workshop, will address the opportunities, technical challenges, and practicalities of space exploration with CubeSats. The workshop will provide a unique environment for open practical collaboration between academic researchers, industry professionals, policy makers and students developing this new and rapidly growing field.

Talks on astrodynamics, attitude control and determination systems, citizen science, citizen space exploration, communications, landers, launch opportunities, open source approaches, outreach, payloads, policy, power systems, propulsion, reentry systems, ride shares, science missions, software, standardization, structures, systems engineering and other related topics are all welcome.

The workshop will be held on or near the Imperial College London campus in South Kensington.

Abstracts due 1st April 2015 via iCubeSat.org

